

# LA GARD



## ELECTRONIC ENTRY DEVICE INSTALLATION INSTRUCTIONS FOR BASIC AND GARD SERIES

# TABLE OF CONTENTS

GENERAL INFORMATION.....	1
ENTRY DEVICE MOUNTING TEMPLATES.....	3
3000, 3715, AND 4715 ENTRY DEVICES.....	4
3035 & 3125 ROUND ENTRY DEVICES.....	5
• Swing Bolt instructions	
• Dead/Spring Bolt instructions	
3710 ANGULAR ENTRY DEVICE.....	7
• Additional instructions 3710 keypad replacement	
3750, 3750-K, 3750KE AND 3190 ENTRY DEVICES.....	8
• Swing Bolt instructions	
• Dead/Spring Bolt instructions	
8130.....	10
2666 KNOB ASSEMBLY.....	11

# ELECTRONIC ENTRY DEVICE

## Installation Instructions

### GENERAL INFORMATION

In order to maintain the highest quality standards and ensure a problem-free application, please read this guide thoroughly before mounting the input unit. The installation instructions are the basis for Security Agency Approvals. The lock installation must be done in accordance to these instructions in order to maintain the labeled approval level.

#### SAFEGUARDS FOR MOUNTING

1. Once an electronic lock has been mounted, no more welding can be done on the safe.
2. Keep metal dust, filings, etc. away from the lock.
3. Keep cables away from sharp edges and moving parts.
4. Never carry keypads or locks by the cable.
5. Use 9-Volt ALKALINE batteries only. The use of a high quality, name brand battery (Energizer® or Duracell®) is recommended.

#### BASIC TOOLS AND MATERIALS REQUIRED:

- Medium Phillips head screwdriver (#2) (recommend magnetized tip)
- Small flat file or deburring stone
- Tape measure or ruler
- ESD wrist band

#### PREPARATION FOR NEW INSTALLATION: (IF REQUIRED)

1. Use the template provided to establish the exact locations (relative to the spindle hole) of the mounting holes for the Entry Device and the lock assembly. Be sure to consider the cable length from the entry device to the lock.
2. The spindle hole diameter can be a minimum of .406" (10.3mm) to a maximum of .438" (11.1mm). The .406" (10.3mm) diameter is recommended. Spindle hole must be deburred.
3. The Entry Device mounting screws require drilled and tapped holes to 3/8" (9.5mm) depth if possible (minimum 1/4" or 6.4mm depth required.) Drill either the two horizontal mounting holes or the two vertical holes.

For Lock installation instructions, refer to 717.088 available at [www.kaba-mas.com](http://www.kaba-mas.com).

---

#### SECURITY RECOMMENDATION:

*Security relevant parts of a high security lock should not be accessible to unauthorized persons when the door of the secure storage unit to which it is fitted is open.*

---

## DIAL RING/FRONT HOUSING BASE MOUNTING TEMPLATE

ENGLISH: #8-32

METRIC: M4-0.7

DRILL AND TAP TO 3/8" or 9.5mm DEPTH

(MIN. 1/4" or 6.4mm)

(2X) AS REQUIRED

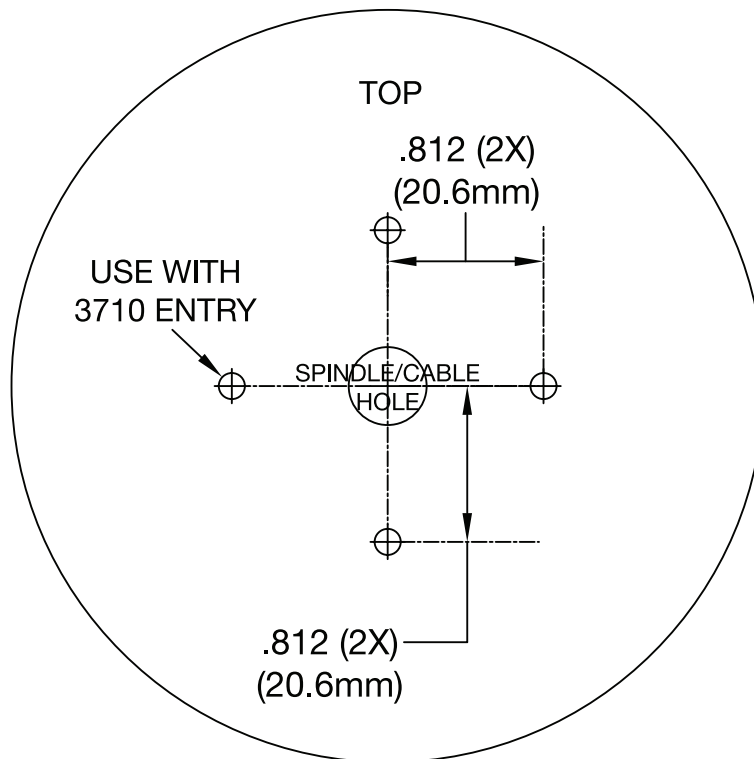

**DO NOT SCALE**

## 8130 ENTRY DEVICE MOUNTING TEMPLATE

ENGLISH: #8-32

METRIC: M4-0.7

DRILL AND TAP TO 3/8" or 9.5mm DEPTH

(MIN. 1/4" or 6.4mm)

(2X) AS REQUIRED FOR MOUNTING METHOD

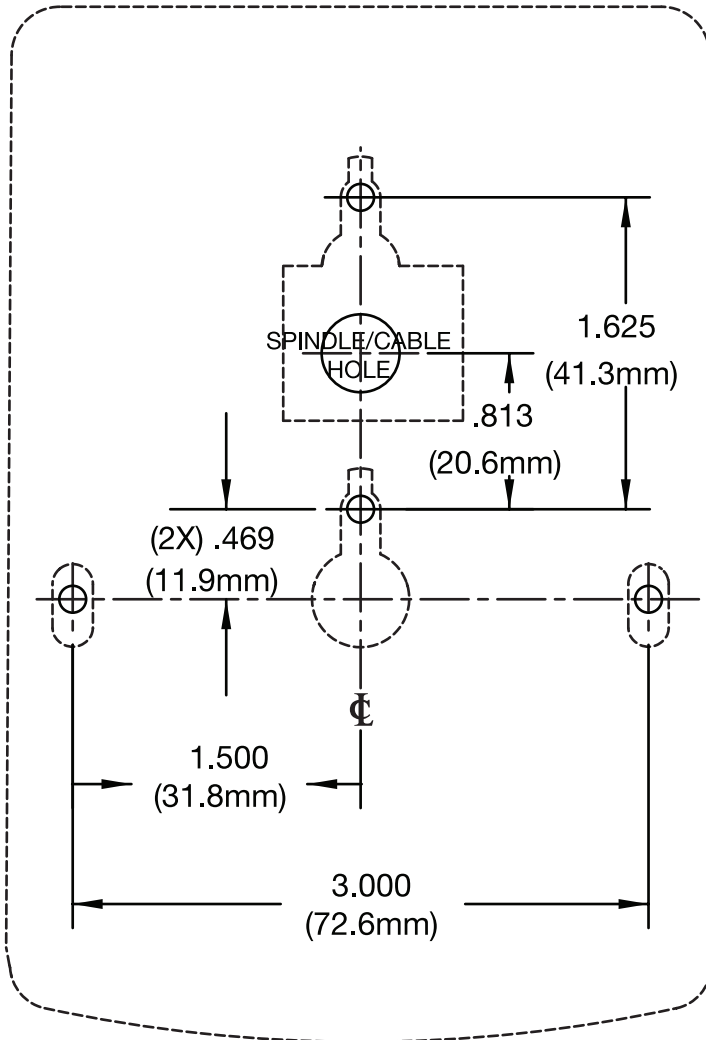

**DO NOT SCALE**

## 3000, 3715 AND 4715 ROUND ENTRY DEVICES

The 3000, 3715 and 4715 Entry Devices are designed with keyhole slots for ease of mounting and battery replacement.

1. Install the two #8-32 shoulder screws (US) or the M4-0.7 shoulder screws (metric) to mount the Entry Device to the door.
2. Feed the key pad cable through the spindle cable hole from the front of the safe door. Leave approximately 2 inches (50mm) of the cable extended out the front of the container door, to allow for battery replacement.
3. Position the Entry Device over the mounting screws and then slide the Entry Device down onto the mounting screws. (Figures 1 & 2)
4. Ensure that the Entry Device cable is running through the channel at the back of the lock.

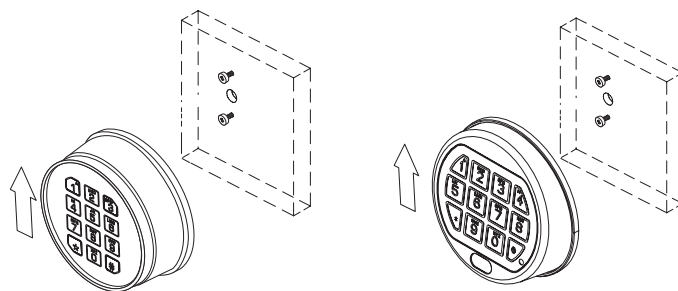
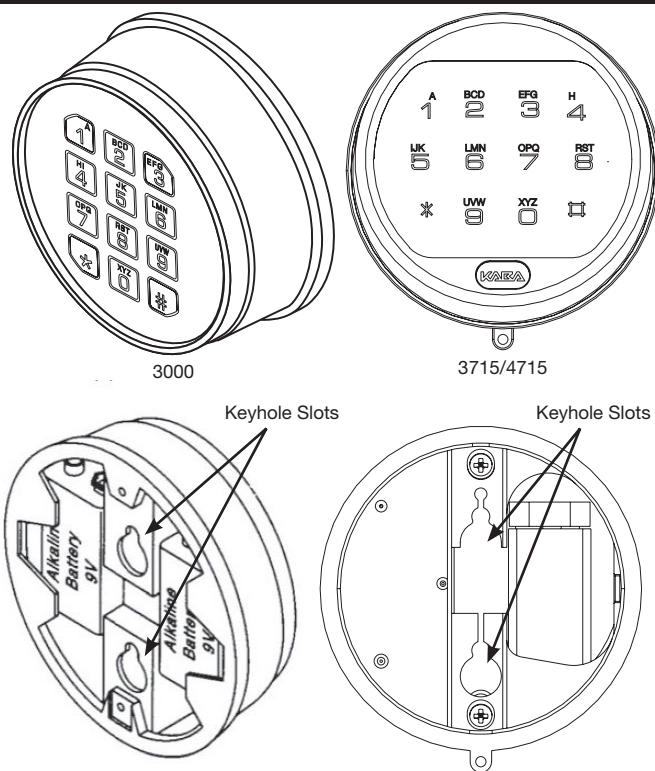

Figure 1

Figure 2

### INSTALLING BATTERIES

1. Slide the keypad housing up and carefully pull away from mounting surface to expose battery compartment.

**CAUTION!** Hold onto the battery connector to avoid pulling the wires out of the board.

2. Connect a new 9-Volt alkaline battery to the battery connector.
3. Push the battery and the leads completely into the battery compartment.
4. Repeat procedure for second battery ( 3000 only).
5. Carefully position the keypad over the mounting screws and slide the keypad housing down. Ensure there are no wires or cables trapped between the Entry Device and the safe door.

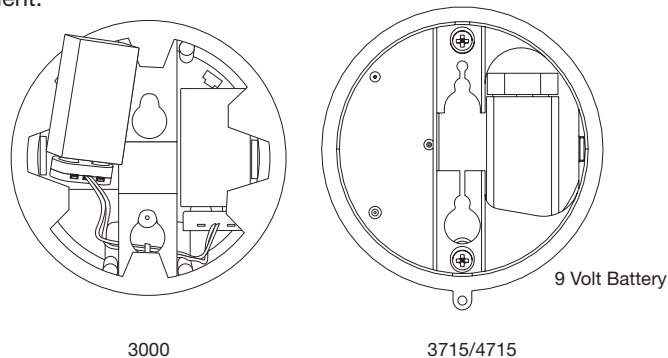

**SWING BOLT**

1. Mount the dial plate (p/n 2676) centered on the through hole. Attach the dial plate with the two mounting screws US 8-32 (US) or the M4-0.7 (metric), and the shoulder bushings (p/n 2618).
2. Slide the bearing plate (p/n 2674) over cable and press onto the fasteners on the Entry Device.
3. Feed the key pad cable through the spindle cable hole from the front of the safe door.
4. Insert the springs (p/n 2893) and blocking pins (p/n 2894) into the hole located on the back of the key pad.
5. Rotate the key pad approx. 30° counter-clockwise and place onto the bushings. Then turn the key pad clockwise until the blocking pin clicks, and secures the Entry Device to the safe door.

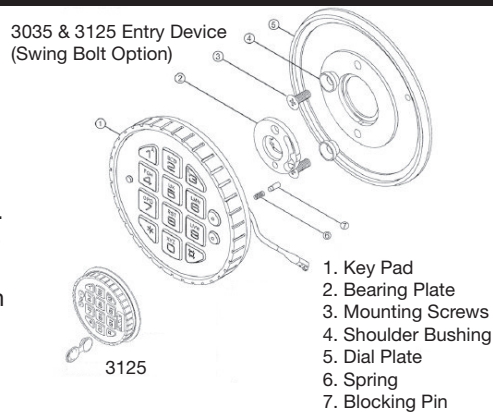

**WARNING:** Once installed, the Entry Device cannot be removed from the safe door without causing physical damage to the Entry Device.

6. When installing the lock, ensure that the Entry Device cable is running through the channel at the back of the lock.

**DEAD/SPRING BOLT**

1. Mount the dial plate (p/n 2676) centered on the through hole. Attach the dial plate with the two mounting screws US 8-32 (US) or the M4-0.7 (metric), and the shoulder bushings (p/n 2618).
2. Measure total mounting thickness (door thickness + mounting plate). (Figure 3)
3. Cut the spindle to a length of .700" (17mm) plus the total mounting thickness.

**NOTE:** the spindle must be deburred.

4. Insert the spindle into the keypad, and route the cable in the groove of the spindle.
5. Slide the bearing plate (p/n 2674) over the cable, and press onto the fasteners on the Entry Device.

**NOTE:** It is important to make sure the cable will not rub on the dial plate after assembly.

6. Feed the Entry Device's cable and spindle through the spindle/cable hole from the front of the safe door.

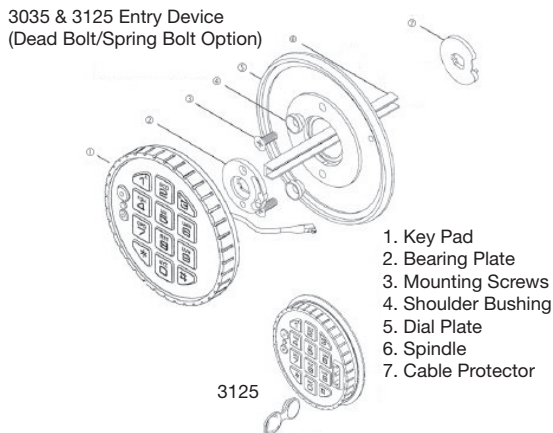

**WARNING:** Spring and blocking pin are NOT installed when Entry Device is used with either the dead bolt or spring bolt locks.

7. Rotate the key pad approx. 30° counter-clockwise and place onto the bushings.
8. Then turn the key pad clockwise until the key pad is vertical (Figure 4).

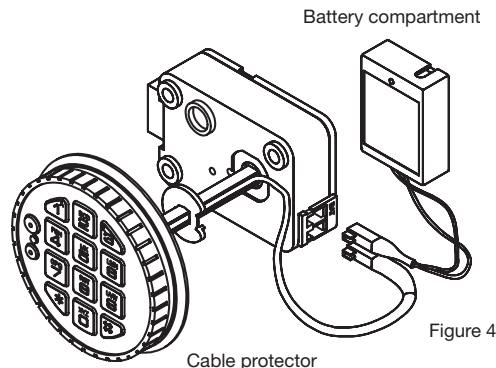
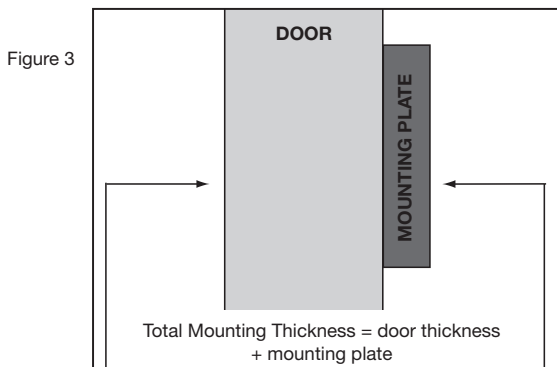

9. The spindle should protrude between .300" - .350" (8 - 9 mm) through the safe door.
10. Slide the cable protector (p/n 2754) over the cable and spindle, until the flat side rests against the inside of safe door. Route the cable through the groove of the cable protector.
11. Gently pull on the cable to assure that there is no excess cable in the spindle hole that would rub on the metal door.
12. Install the lock with the bolt extended onto the spindle.



## INSTALLING BATTERIES

The 3035/3125 Entry Device required either a battery box (2788 or 4001), or a battery/alarm box (2789 or 4002) to provide power to the lock.

Mount the battery box inside the safe, and connect the cable coming from the battery box directly into the connector port marked BAT on the lock.

### Small Battery and Battery/Alarm Box:

1. Open safe door.
2. Remove battery box cover by pulling the front portion away from the safe door.

---

**CAUTION!** Hold onto the battery connector to avoid pulling the wires out of the board.

---

3. Connect a new 9-Volt alkaline battery to the battery connector.
4. Push the battery and the leads completely into the battery compartment.
5. Replace the cover and test the lock several times before closing the door.

### Large Battery and Battery/Alarm Box:

1. Open safe door.
2. Remove battery box cover by pulling the front portion away from the safe door.
3. Insert six new "C" cell alkaline batteries
4. Replace the cover and test the lock several times before closing the door.

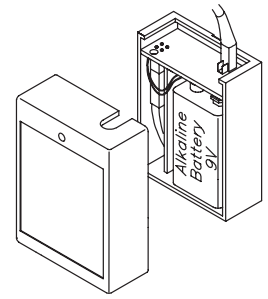

2788 Small Battery Box or  
2789 Small Battery Alarm Box

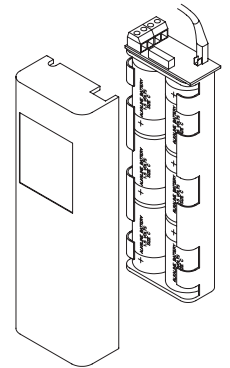

4001 Large Battery Box  
4002 Large Battery Alarm Box



## 3710 ANGULAR ENTRY DEVICE (ADDITIONAL INSTRUCTIONS 3716 ADAPTER)

### The 3710 Entry Device comes with the mylar portion of the keypad unattached.

1. Feed the key pad cable through the spindle cable hole from the front of the safe door. (Figure 5).
2. Position the Entry Device over the screw holes on the door, and lift the keypad to expose the mounting holes.
3. Install the two #8-32 screws (US) or the M4-0.7 screws (metric) to mount the Entry Device to the door.

**NOTE:** Ensure that the battery connector is routed through the battery open at the bottom of the housing, and no wires are pinched under the housing.

4. Remove the adhesive strip from the back of the keypad and carefully align before adhering to the housing (Figure 6). Prior to adhering, make sure that the housing is completely free of debris such as filings, dust, etc., for the best possible contact.

**WARNING:** Once installed, the Entry Device cannot be removed from the safe door without causing physical damage to the keypad.

5. Ensure that the Entry Device cable is running through the channel at the back of the lock. Refer to lock installation instructions which are available at [www.kaba-mas.com](http://www.kaba-mas.com).

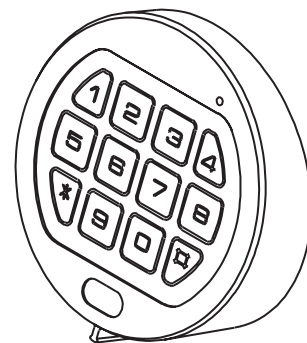

3710

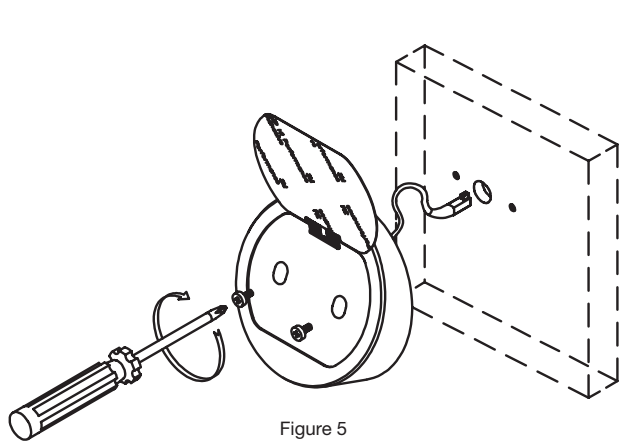

Figure 5

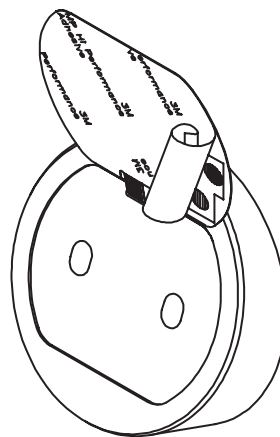
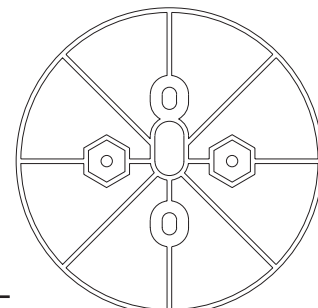
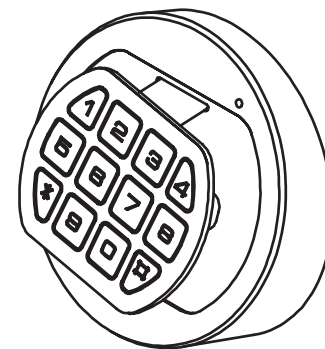

Figure 6



3716

### ALTERNATE INSTALLATION

The option adapter plate (p/n 3716) may be used to mount the 3710 Entry Device to a safe with vertical mounting hole (12 and 6 o'clock).

1. Mount the adapter plate centered on the through hole. Attach the dial plate with the two mounting screws US 8-32 (US) or the M4-0.7 (metric). Then follow the above installation instructions.

**NOTE:** To maintain A2P/EN1300 Agency Certification, tamper evident seals must be placed on entry. Please refer to document P/N 7025.0514 for more information.

### BATTERY INSTALLATION

1. If installed, remove black plastic battery compartment cover (located at the bottom of the keypad) by gently pulling downward on its handle.
2. Allow the battery connector and its attached leads to drop down and out of the battery compartment. If it does not drop, gently pull on the battery connector until it does.

**CAUTION!** Hold onto battery terminal connector to avoid pulling the wires out of housing.

3. Connect a new 9-Volt alkaline battery to the battery connector.
4. Push the battery and the leads completely into the battery compartment.
5. Install the battery cover by placing one side of the cover in position and then pressing the other side into position with your finger.

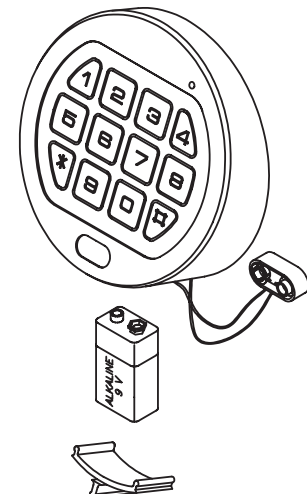

**SWING BOLT**

1. Mount the dial plate (p/n 3752) centered on the through hole (Figure 6). Attach the dial plate with the two mounting screws US 8-32 (US) or the M4-0.7 (metric).
2. Slide the bearing plate (p/n 2674) over cable and press onto the fasteners on the Entry Device (Figure 7).
3. Feed the key pad cable through the spindle cable hole from the front of the safe door.
4. Insert the two springs (p/n 2893) and blocking pins (p/n 2894) into the holes located on the back of the keypad (Figure 8).
5. Rotate the key pad approx. 30° counter-clockwise and place keypad bushings into the large openings on the dial plate. Then turn the key pad clockwise until the blocking pin clicks, and secures the Entry Device to the safe door.

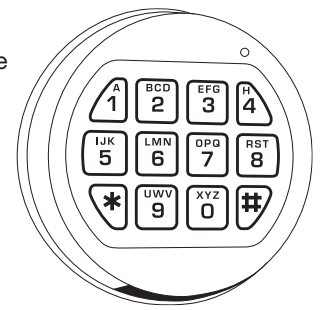

3750, 3750-K

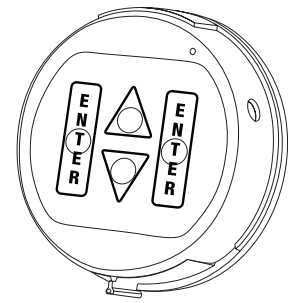

3190

**WARNING:** Once installed, the Entry Device cannot be removed from the safe door without causing physical damage to the Entry Device.

6. When installing the lock, ensure that the Entry Device cable is running through the channel at the back of the lock. Refer to lock installation instructions which are available at [www.kaba-mas.com](http://www.kaba-mas.com).

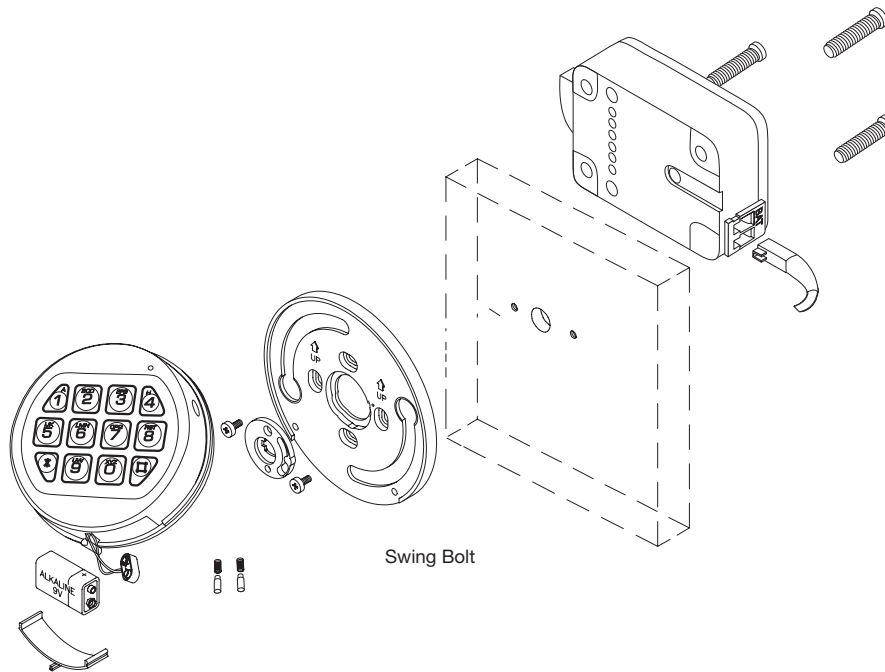

Swing Bolt

Mounting Screws

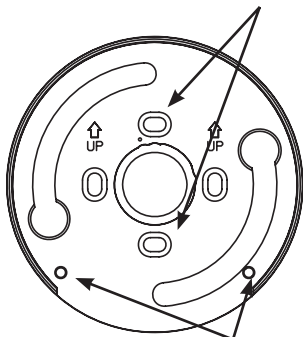

Pins & Springs

Figure 6

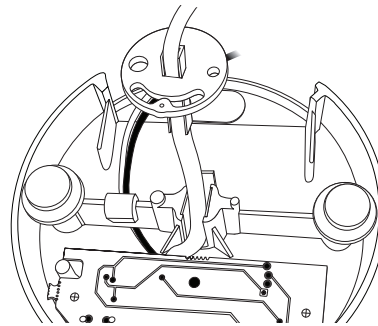
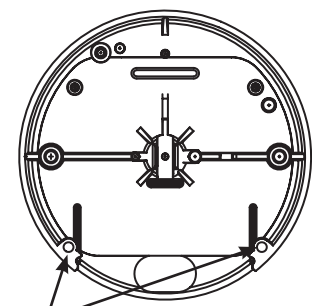

Figure 7



Insert Springs & Pins

Figure 8

## DEAD BOLT/SPRING BOLT

1. Mount the dial plate (p/n 3752) centered on the through hole (Figure 6). Attach the dial plate with the two mounting screws US 8-32 or the M4-0.7 (metric) making sure to rotate the dial plate counter clockwise prior to tightening down.

**NOTE:** *the spindle must be deburred but not rounded off.*

2. Insert the spindle into the keypad, making certain it is fully seated; route the cable in the groove of the spindle (Figure 7).
3. Route the cable either under the spindle or between the circuit board and the spindle.
4. Slide the bearing plate (p/n 2674) over the cable, and press onto the fasteners on the Entry Device.

**NOTE:** *It is important to make sure the cable will not rub on the dial plate after assembly.*

5. Feed the Entry Device's cable and spindle through the spindle/cable hole from the front of the safe door.

**WARNING:** *Spring and blocking pin are NOT installed when Entry Device is used with either the dead bolt or spring bolt locks.*

6. Rotate the key pad approx. 30° counter-clockwise and place keypad onto the dial plate bushings.
7. Then, turn the key pad clockwise until it is vertical.
8. Mark the spindle protruding through the safe door and mounting plate to be cut so that .354" (9mm) will be protruding after cutting to length (Figure 9).

**NOTE:** *If cutting several spindles at one time based on door thickness (i.e. door + mounting plates), add 1.125" to door thickness and cut spindle length "L" to +/- .005 tolerance. If door thickness varies +/- .XXX (tolerance), then the spindle length "L" should be adjusted accordingly; i.e. for -.XXX shorten spindle this amount; for +.XXX lengthen spindle this amount. Amount of spindle protruding through the safe door should be about .354" (9mm).*

**NOTE:** *When deburring the spindle, make sure not to remove too much material from the spindle.*

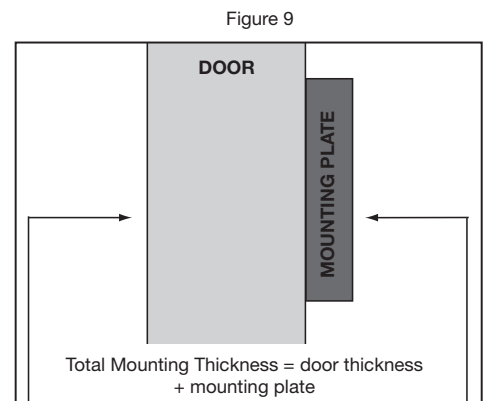
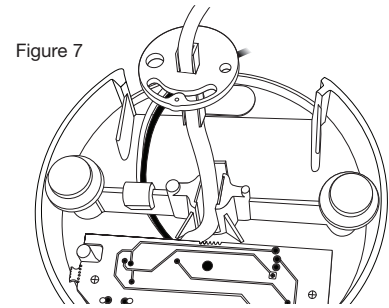
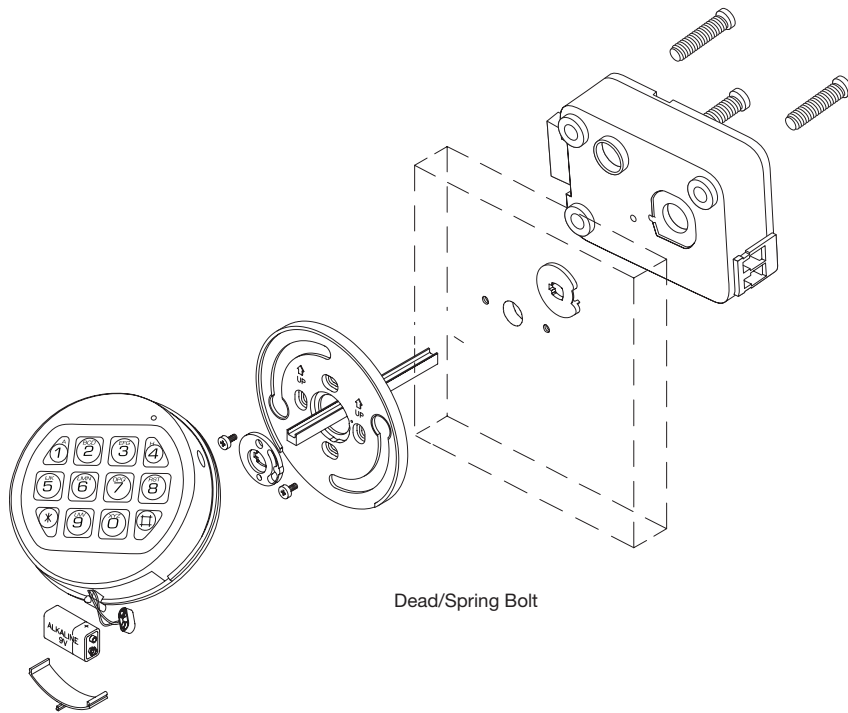

9. Rotate the keypad approximately 30 degrees and remove from dial plate.
10. Remove spindle and cut as marked in step 8 above.
11. Repeat steps 2 thru 7.
12. The spindle should protrude about .354 (9mm) through the safe door.
13. Slide the cable protector (p/n 2754) over the cable and spindle, until the flat side rests against the inside of safe door. Route the cable through the groove of the cable protector.
14. Gently pull on the cable to assure that there is no excess cable in the spindle hole that would rub on the metal door.
15. Install the lock with the bolt extended onto the spindle. Refer to lock installation instructions which are available at [www.kaba-mas.com](http://www.kaba-mas.com).

**BATTERY INSTALLATION**

1. If installed, remove black plastic battery compartment cover (located at the bottom of the keypad) by gently pulling downward on its handle.
2. Allow the battery connector and its attached leads to drop down and out of the battery compartment. If it does not drop, gently pull on the battery connector until it does.

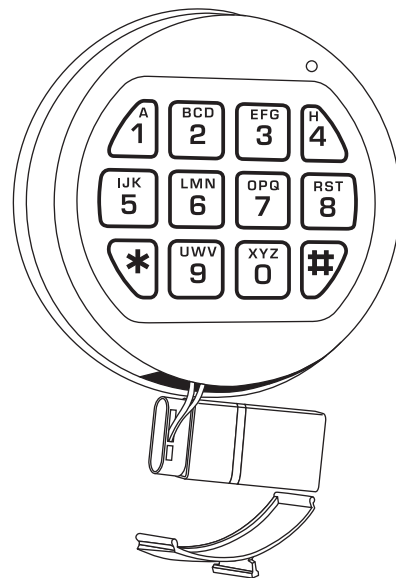

**CAUTION!** Hold onto battery terminal connector to avoid pulling the wires out of housing.

3. Connect a new 9-Volt alkaline battery to the battery connector.
4. Push the battery and the leads completely into the battery compartment.
5. Install the battery cover by placing one side of the cover in position and then pressing the other side into position with your finger.

**Standard method**

The 8130 Entry Device comes with a backplate with keyhole slots for ease of mounting (Figure 10).

1. Locate, drill and tap holes to mount the Entry Device to the outside of the safe door using the installation template provided.
2. Install the two #8-32 shoulder screws (US) or the two M4-0.7 shoulder screws (Metric) on the front of the safe door to mount the Entry Device to the door (Figure 11).
3. Feed the Entry Device cable through the spindle cable hole from the front of the safe door (Figure 12).
4. Position the keyhole slotted holes on the backplate of the Entry Device over the mounting screws and then slide the Entry Device down onto the mounting screws.
5. Remove the adhesive strip from the back of the keypad and carefully align before adhering to the housing. Refer to lock installation instructions which are available at [www.kaba-mas.com](http://www.kaba-mas.com).

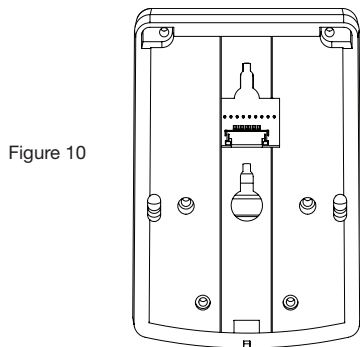

Figure 10

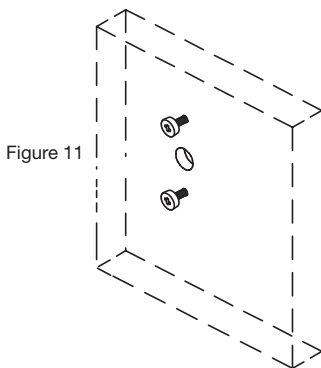

Figure 11

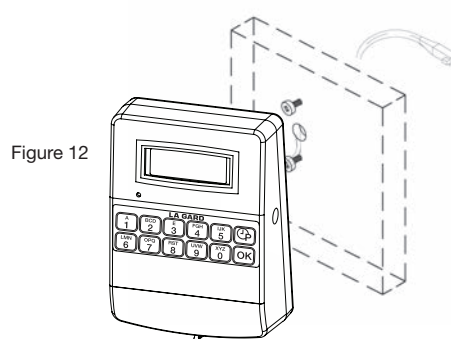

Figure 12

**8130 alternate method (tamper evident for VdS and A2P approval)**

The 8130 Entry Device comes with the mylar portion of the keypad unattached (Figure 13).

1. Locate, drill and tap holes to mount the Entry Device to the outside of the safe door using the installation template provided.
2. Feed the Entry Device cable through the spindle/cable hole from the front of the safe door.
3. Install the two M4-0.7 Phillips screws through the front of the housing to mount the Entry Device to the door (Figure 13).

**WARNING:** 8130 Before completing the next step, you should ensure that the jumper switches for time delay/open window are set as desired.

4. Remove the adhesive strip from the back of the keypad and carefully align before adhering to the housing.

In order to use either the Dead bolt or Spring bolt locks, with Entries 3000, 3710, 3715, and 8130 a method of retracting the bolt will be required. Knob Assembly (p/n 2666) is recommended.

5. For A2P/EN1300 Certification, please refer to document P/N 7025.0514.

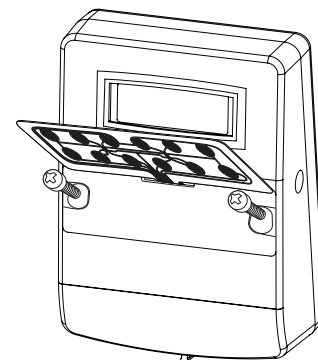
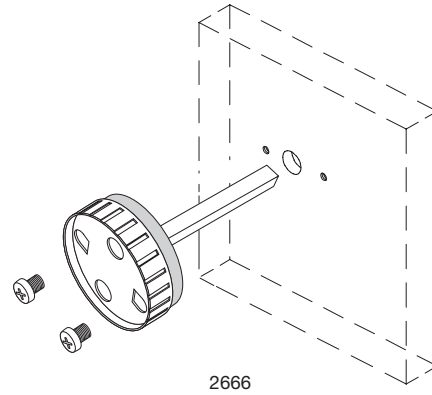

Figure 13



The holes required to mount the knob need to be drilled 1.25" apart and must be centered over the spindle hole.

1. To install the Knob Assembly, remove the insert from the front of the knob.
2. Cut the spindle to a length of .820" (20.8mm) plus the door thickness (Figure 14).

---

**NOTE:** *the spindle must be deburred.*

---

3. Install the knob assembly using the two 8-32 X 5/16 phillips pan screws.
4. Install the lock (with the bolt extended) onto the spindle, placing it flush to the mounting surface. Refer to lock installation instructions which are available at [www.kaba-mas.com](http://www.kaba-mas.com).

Figure 14

